

1.0 INTRODUCTION

The products described in this manual are manufactured or distributed by Reliance Electric Industrial Company.

The AutoMax[®] Remote I/O network interconnects an AutoMax or DCS 5000 Processor with remote AutoMax racks, Remote I/O Heads, or remote Shark[™] racks. The AutoMax Remote I/O Communications module (M/N 57C416) is the interface between the AutoMax or DCS 5000 Processor and the remote I/O on the network.

The AutoMax Remote I/O network is designed for master/slave operation. The network is composed of two main parts: a number of nodes (drops) and a transmission medium (coaxial or fiber-optic cable).

There are two types of drops: master and slave. The master drop is a Multibus[™] rack that contains at least one AutoMax or DCS 5000 Processor module and a Remote I/O Communications module.

Slave drops can be:

- Remote I/O Heads (M/N 57C328 and M/N 57C330)
- Remote Drive Interface Heads (M/N 57C329)
- Shark racks containing I/O modules and an AutoMax Remote I/O Shark Interface module (M/N 57C554)
- AutoMax racks containing AutoMax I/O modules and a Remote I/O Communications module
- IBM-compatible personal computers containing the AutoMax PC Link Interface module (M/N 57C445). Refer to the AutoMax PC Link instruction manual (J2-3011) for more information.

An AutoMax Remote I/O network can have a maximum of seven slave drops. All five types can be mixed on the same network.

The drops are connected using coaxial cable or, when noise immunity and total electrical isolation is required, fiber-optic cable. The coaxial cable network is structured in a bus configuration. This type of topology is characterized by a main trunkline in which individual nodes are connected in a multidrop fashion as shown in figure 1.1.

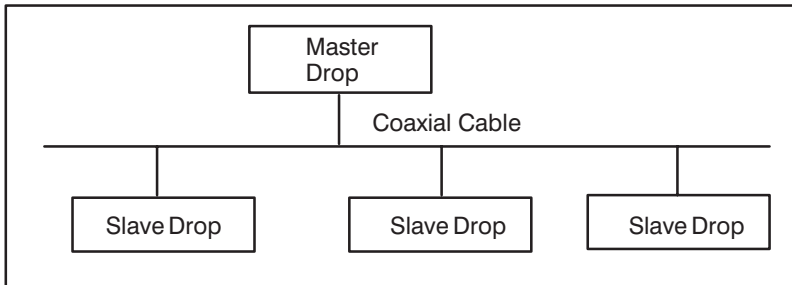

Figure 1.1 - A Typical Coaxial Cable Remote I/O Network

The black bar shown on the right-hand margin of this page will be used throughout this instruction manual to signify new or revised text or figures.

The fiber-optic cable network is organized in an active star configuration. With this type of topology, each node is connected to a multi-port central point, also referred to as a "hub," containing active re-transmitting devices as shown in figure 1.2.

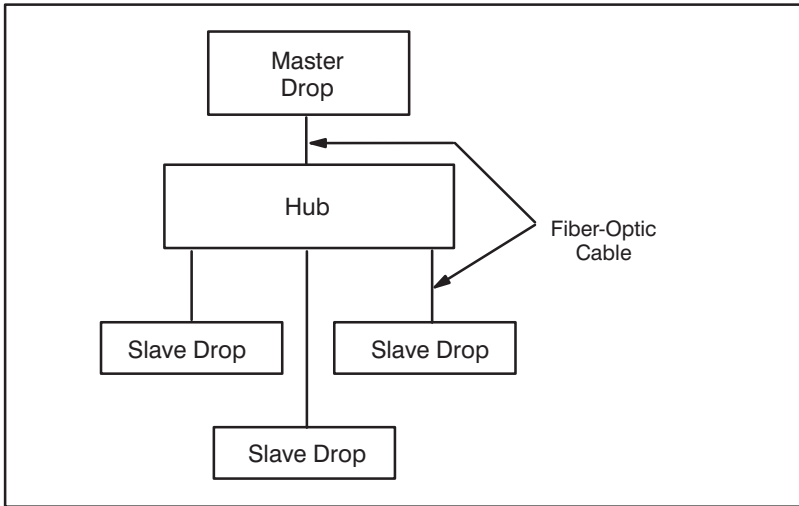

Figure 1.2 - A Typical Fiber-Optic Cable Remote I/O Network

The type of cable used (whether coaxial or fiber-optic) does not affect the operation of the Remote I/O network protocols, application software, or the operation of the Remote I/O Communications module, Shark Interface module, Remote I/O Head, or Remote Drive Interface Head.

The Remote I/O Communications module in the master drop (drop 0) rack functions as the network's Remote I/O master. Master or slave Remote I/O Communications modules may be installed in any slot in the rack. Any number of Remote I/O Communications modules can be installed in a master rack, each controlling a separate Remote I/O network. See figure 1.3.

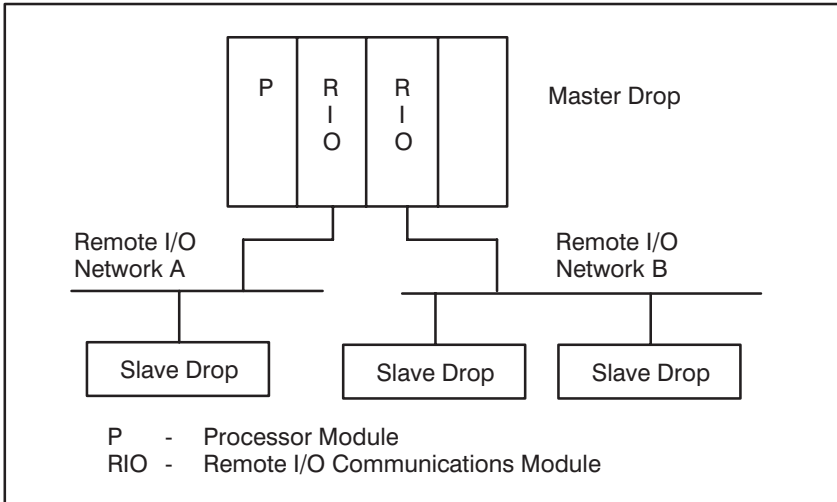

Figure 1.3 - Multiple Remote I/O Network Connections (Coax)

The master initiates and controls all data transmissions on the network by polling every slave drop in a round-robin sequence. A slave drop's Remote I/O Communication module, Remote I/O Head, or AutoMax Remote I/O Shark Interface module functions as an I/O scanner: it reads data in from the input modules and writes data out to the output modules. The data sent from the master drop to the slave updates the status of the slave's outputs. The slave drop sends the current status of its inputs back to the master.

Each Remote I/O Communications module contains a 4K word dual-port memory for storing the data that is transmitted over the network. Dual-port memory is accessible to both the module and the AutoMax Processor in the rack. In the master module, the dual-port memory contains an image of the status of all the inputs and outputs of the I/O modules in the slave drops. The application task that controls the I/O associated with these I/O modules actually examines the inputs and controls the outputs in the image area.

The Remote I/O Communications module provides an RS-232 compatible serial port and the associated software needed to monitor the status of the drops. An ASCII terminal or a personal computer running terminal-emulation software are also required. For more information, refer to section 5.0.

The remainder of this manual describes the functions and specifications of the Remote I/O Communications module, Remote I/O Head, Remote Drive Interface Head, and the AutoMax Remote I/O Shark Interface module. It also includes installation and troubleshooting procedures, as well as configuration and programming information.

1.1 Related Publications

Related publications that may be of interest:

- J-3012 AutoMate/AutoMax Digital I/O Rail and Modules Manual
- J-3650 AutoMax Processor Module Instruction Manual
- J-3675 AutoMax Enhanced Basic Language Instruction Manual
- J-3676 AutoMax Control Block Language Instruction Manual
- J2-3094 AutoMax Enhanced Ladder Language Instruction Manual
- J-3809 Shark XL II Programmable Controller Instruction Manual
- J2-3018 Shark XL I/O System Instruction Manual
- D2-3170 Rail Interface Card Instruction Manual
- Various AutoMax Programming Executive instruction manuals
- IEEE 518 Guide for the Installation of Electrical Equipment to Minimize Electrical Noise Inputs to Controllers From External Sources
- Your personal computer and DOS operating system manual(s).
- Other instruction manuals applicable to your hardware configuration.

1.2 Related Hardware and Software

Model number (M/N) 57C416 contains one Remote I/O Communications module.

M/N 57C554 contains one AutoMax Remote I/O Shark Interface module.

M/N 57C328 and M/N 57C330 each contain one AutoMax Remote I/O Head.

M/N 57C329 contains one AutoMax Remote Drive Interface Head.

The Remote I/O Communications module, the AutoMax Remote I/O Head, the AutoMax Remote Drive Interface Head, and the AutoMax Remote I/O Shark Interface module can be used with all versions of the AutoMax and DCS 5000 Processor.

Remote I/O communications is supported by all versions of the AutoMax Programming Executive software.

1.3 Terms and Conventions Used in This Manual

Throughout this instruction manual, certain terms will be used for brevity and clarity.

A Remote I/O Communications module (M/N 57C416) will be referred to as a **Remote I/O module**.

A remotely-located AutoMax/DCS 5000 rack containing I/O modules and a Remote I/O Communications module will be referred to as a **Multibus drop**.

An AutoMax Remote I/O Head (M/N 57C328 or M/N 57C330 with AutoMate digital and analog I/O Rails and Local I/O Heads connected will be referred to as a **Remote I/O Head drop**.

An AutoMax Remote Drive Interface Head (M/N 57C329) with a drive connected will be referred to as a **Remote Drive Interface Head drop**.

A Shark rack containing I/O modules and an AutoMax Remote I/O Shark Interface module (M/N 57C554) will be referred to as a **Shark drop**.

An AutoMax Remote I/O Shark Interface module will be referred to as a **Shark Interface module**.

Unless otherwise stated, the material presented in this instruction manual applies to the Remote I/O module, Remote I/O Head, Remote Drive Interface Head, and the Shark Interface module. Any differences between these products will be pointed out explicitly