

2.0 I/O RAIL

2.1 Introduction

This chapter describes the I/O rail, its mounting instructions, and I/O wiring.

2.2 General Description

The I/O rail (M/N 45C1) can accommodate eight plug-in digital I/O modules, for a total of 16 I/O channels. When used with an AutoMate system the eight modules may be any combination of input or output modules. When used with a DCS 5000/AutoMax system a rail can hold either all input modules or all output modules, but not both. When used with a Distributed Power DCS 5000/AutoMax system a rail can hold any combination of input or output modules. Each I/O rail is made up of:

- a rail (or chassis)
- a terminal strip
- a motherboard

2.2.1 Rail Chassis

The rail is made of aluminum and measures 9 inches (22.9 cm) (H) x 5.5 inches (14.0 cm) (W) x 7.5 inches (19.1 cm) (D). The terminal strip and I/O motherboard mount on the chassis as shown in figures 2.1 and 2.2. The chassis also serves as a heat sink for the I/O modules.

The rail has a threaded groove on one of the cooling fins. You use this threaded groove to attach a wire channel or tray to the side of the rail, if needed. You can use number 10-32 screws which are 3/8 of an inch long to fasten the wire channel to the rail at any point along the cooling fin as shown in figure 2.10. There are four holes in the rail's backplate for mounting it in an enclosure or cabinet. See section 2.3 for installation instructions.

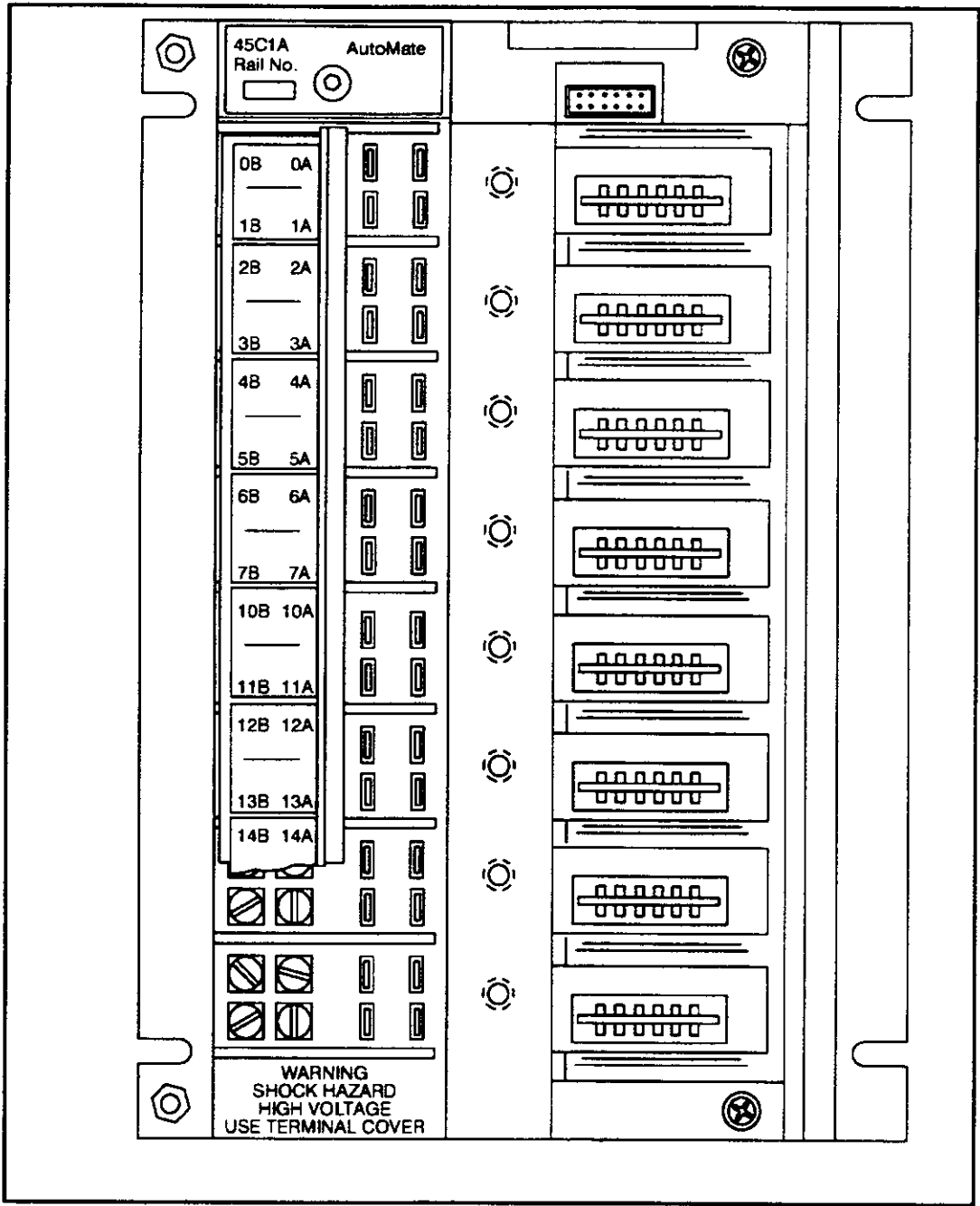

Figure 2.1 - I/O Rail (Front View)

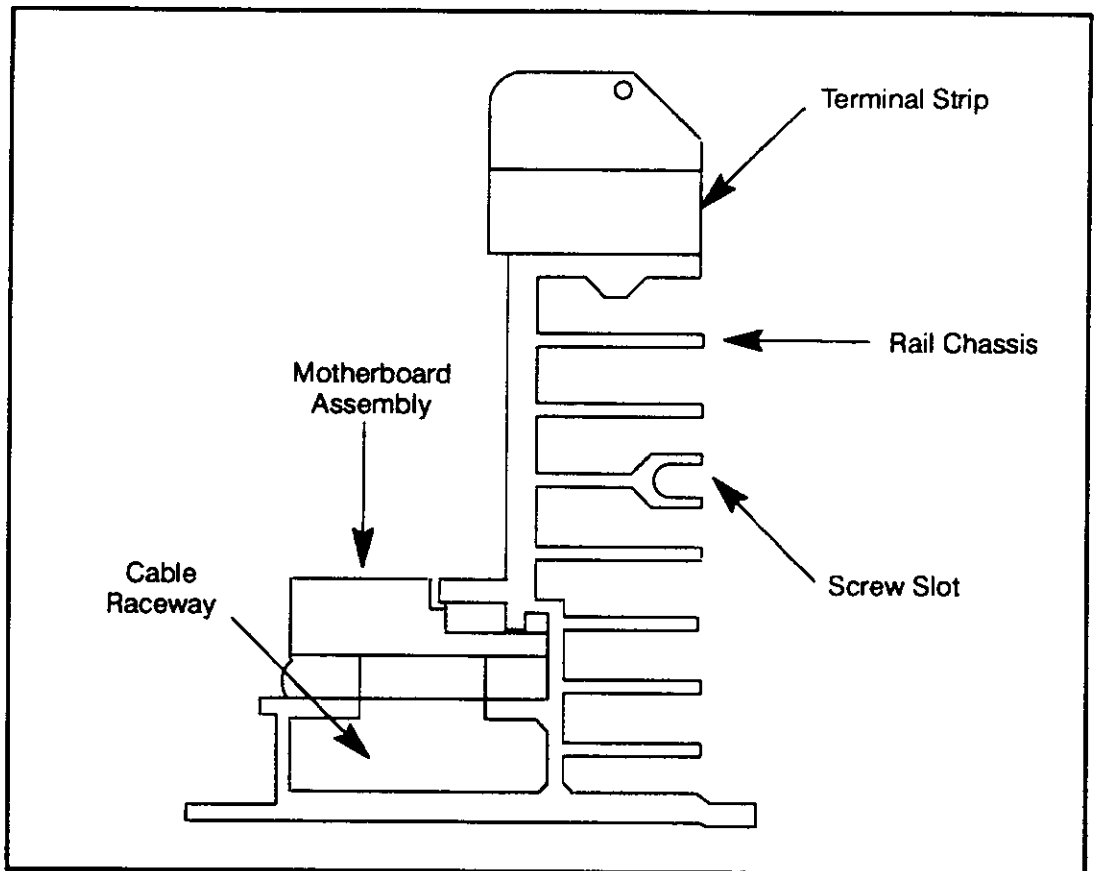

Figure 2.2 - I/O Rail (Top View)

2.2.2 Rail Terminal Strip

The rail's terminal strip provides:

- a termination for field wiring
- mounting slots for plug-in I/O modules
- a place for labeling your wiring
- an insulated safety cover over the terminals.

Field wiring connects directly to the rail's terminal strip. The terminals are arranged in two tiers as shown in figure 2.3. Each terminal is capable of holding two number 12 AWG (3.30 mm²) wires. The smallest recommended wire size is number 22 AWG (0.32 mm²).

There are two terminals (A, B) per I/O channel. Terminal A is the upper terminal and terminal B is the lower terminal. The type of I/O you use will determine which terminal is common or power.

The I/O modules plug into the terminal strip, which connects them to the field wiring. You can install or replace the modules without having to remove the field wiring.

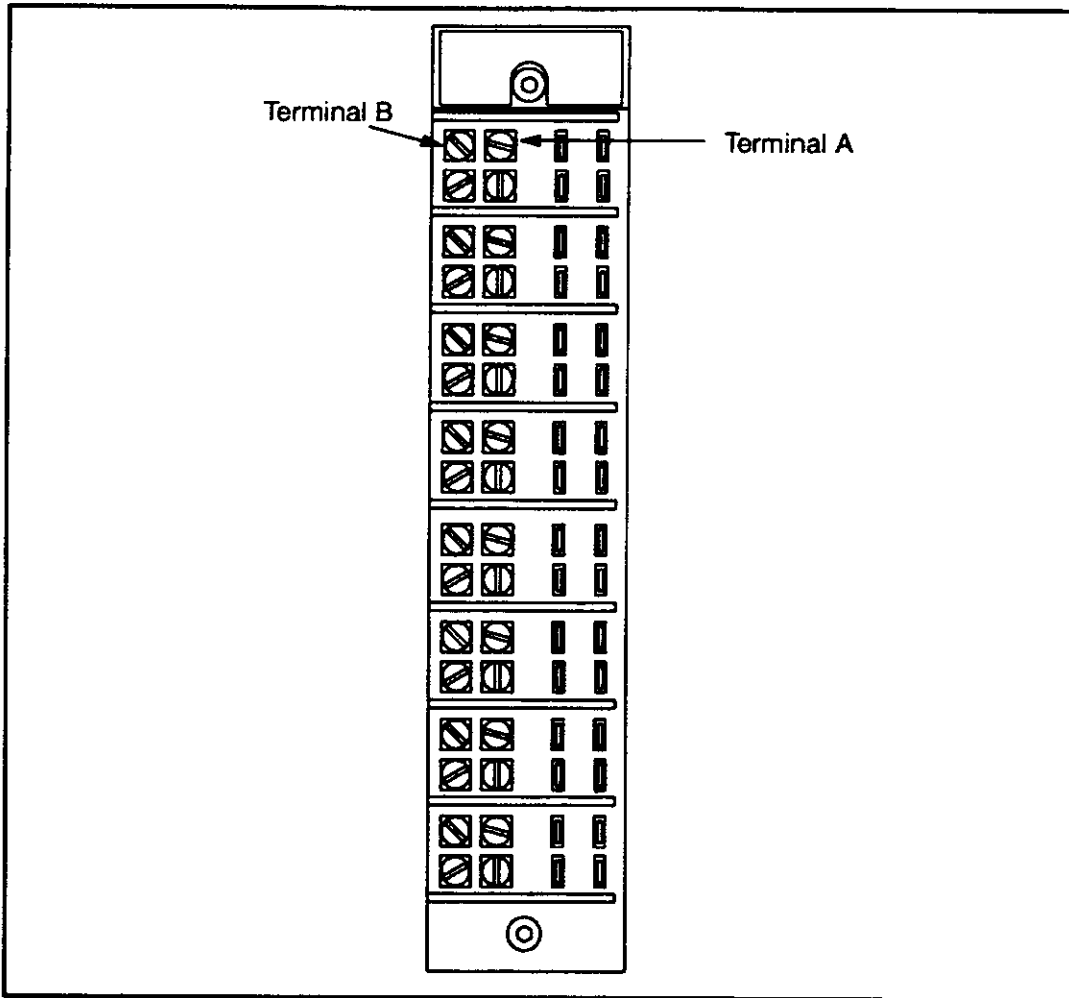

Figure 2.3 - Rail Terminal Strip

Identification labeling is provided on the terminal strip. The cover (P/N 802802-2B) over the terminals, shown in figure 2.4A, is pre-labeled (on both sides) with the I/O addresses of the 16 I/O points per rail. The 16 AutoMate I/O points are numbered in octal from 0-17. When a rail is used with a DCS 5000/AutoMax system, the I/O label addresses are in decimal (0-15). A separate label with the decimal addresses is included with the rail. On the back side of the cover plate, a labeling area is provided to allow you to identify the wire number of each connected device.

The AutoMate terminal strip label part number is 707207-4A. The DCS 5000/AutoMax terminal strip label part number is 707207-4E.

On the top front of the terminal strip, a label is provided for you to list the rail's number as shown in figure 2.4B. A stick-on label that identifies the type of I/O module is provided with each module. There is an area on the side of the terminal strip next to each of the eight module positions for you to place this label. See figure 2.4C.

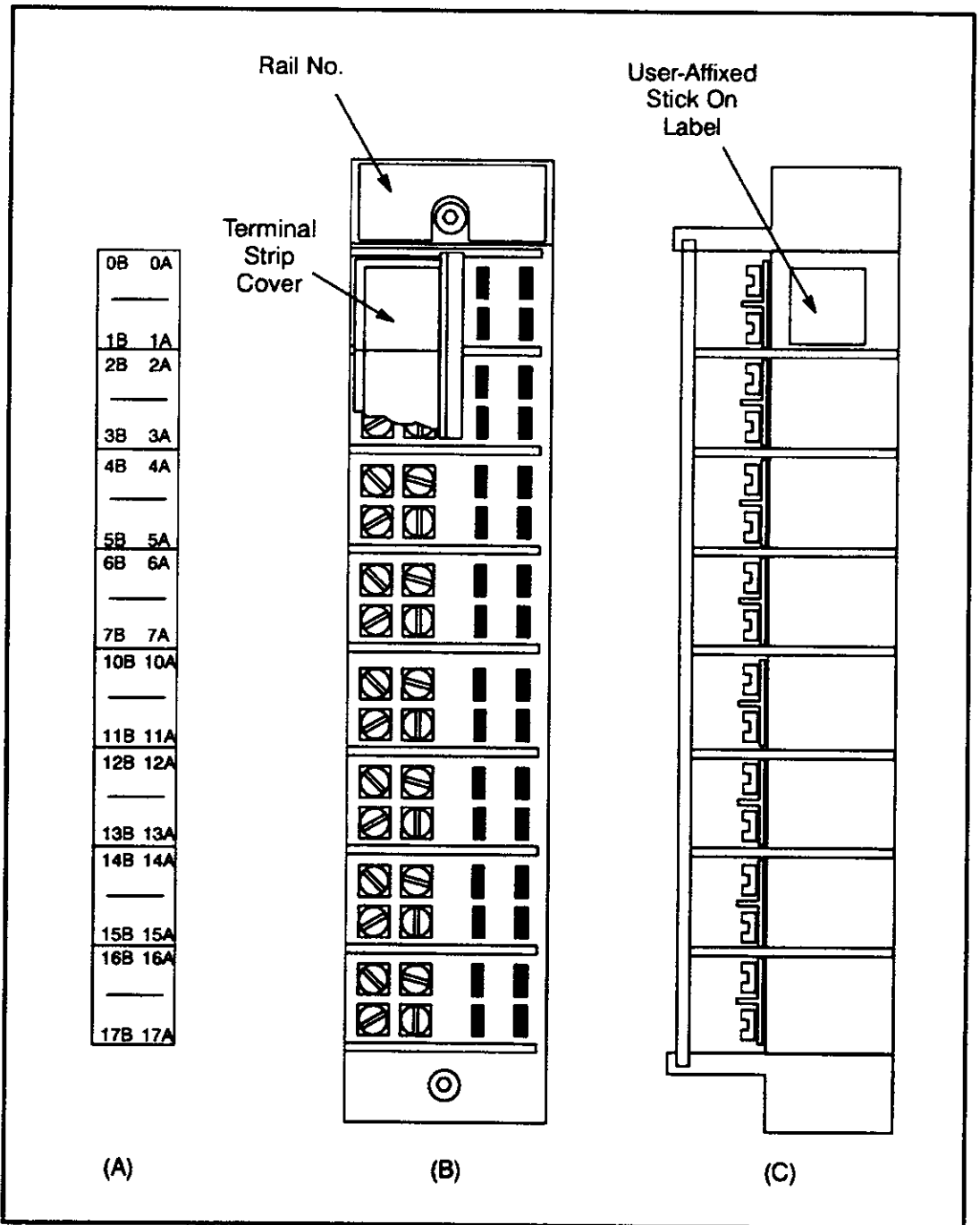

Figure 2.4 - Terminal Strip Assembly

2.2.3 Rail Motherboard

The rail motherboard (M/N 45C2A) is enclosed in a plastic housing and functions as the interface between the digital I/O and the AutoMate or DCS 5000/AutoMax processor. See figure 2.5. The motherboard is mounted on the back of the rail chassis and is held in place by two screws.

In operation, the motherboard:

- automatically detects the type of I/O module, either input or output
- decodes the I/O address of each I/O point in the rail
- communicates with the processor by sending and receiving the I/O status of the 16 points on the rail.

The rail is connected via an I/O Rail Interconnect Cable (M/N 45C5) to the I/O port of one of the following, depending on the equipment selected: an AutoMate processor, a Local I/O Head, a Remote I/O Head, a Local I/O Processor, a Distributed Power PMI Processor, or a DCS 5000/AutoMax Remote I/O Head. This cable provides power to the rail and the logic side of the modules. It also provides communication to and from the processor. The length of the cable is 48 inches (1.2 m). It has a female connector on each end.

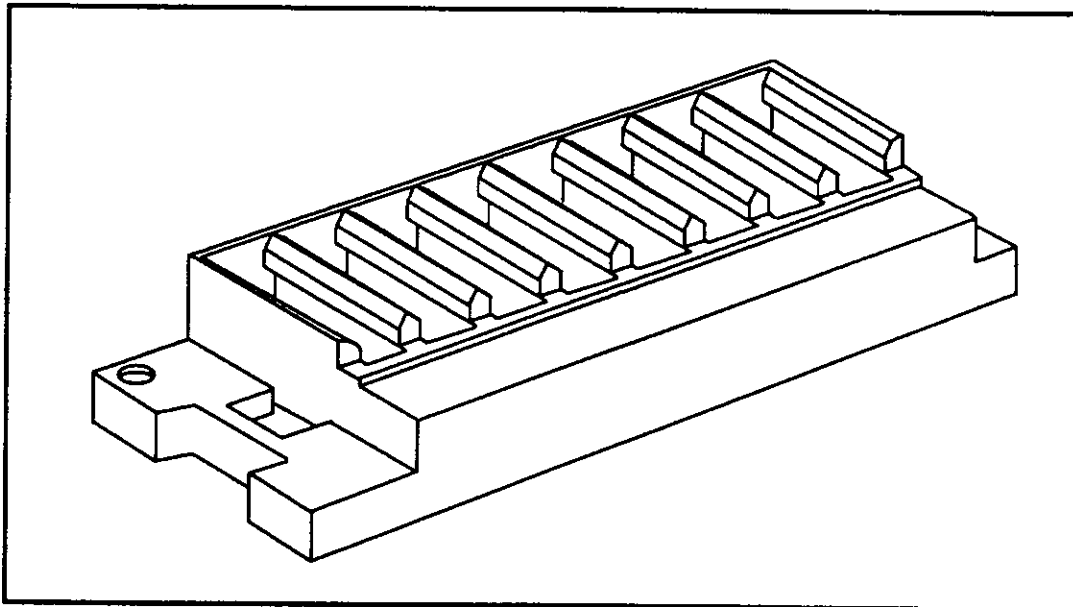

Figure 2.5 - Rail Motherboard

2.3 Rail Installation and Mounting

DANGER

ONLY QUALIFIED ELECTRICAL PERSONNEL FAMILIAR WITH THE CONSTRUCTION AND OPERATION OF THIS EQUIPMENT AND THE HAZARDS INVOLVED SHOULD INSTALL, ADJUST, OPERATE, OR SERVICE THIS EQUIPMENT. READ AND UNDERSTAND THIS MANUAL IN ITS ENTIRETY BEFORE PROCEEDING. FAILURE TO OBSERVE THIS PRECAUTION COULD RESULT IN SEVERE BODILY INJURY OR LOSS OF LIFE.

DANGER

THE USER IS RESPONSIBLE FOR CONFORMING TO THE NATIONAL ELECTRIC CODE AND ALL OTHER APPLICABLE LOCAL CODES WITH RESPECT TO WIRING, GROUNDING, DISCONNECTS, AND OVERCURRENT PROTECTION. FAILURE TO OBSERVE THIS PRECAUTION COULD RESULT IN SEVERE BODILY INJURY OR LOSS OF LIFE.

Use the following procedure to install a rail:

- Step 1. Attach the rail to a flat mounting surface. Figure 2.6 and Appendix A show the mounting dimensions. Figure 2.7 shows two examples of how to attach a rail to its mounting surface. A rail without modules weighs 3 pounds, 15 ounces (1.8 kg).
The rails are designed to be mounted vertically using #10 bolts or studs in an area which allows air flow for cooling.
- Step 2. Connect the I/O Rail Interconnect Cable between the rail and the AutoMate processor, Local I/O Head, Remote I/O Head, Local I/O Processor, a Distributed Power PMI Processor, or DCS 5000/AutoMax Remote I/O Head. The cable is 48 inches (1.2 m) long. Be sure the cable will reach the rail as you design your installation. Place the cable in the rail's cable raceway. See figure 2.2.
Figure 2.8 shows some typical rail installations.
- Step 3. Ground the rail as explained in section 2.3.1.
- Step 4. If your installation requires them, attach the wire channels as described in sections 2.3.2 and 2.3.3.
- Step 5. If your installation requires them, connect the rail jumper bars as described in section 2.3.4.
- Step 6. Connect the I/O wiring as described in section 2.4.
- Step 7. Place the modules' identification stickers on the side of the terminal strip. Insert the modules into the rail's terminal strip and the motherboard. Tighten the screw on the front of the module to securely hold it to the rail.

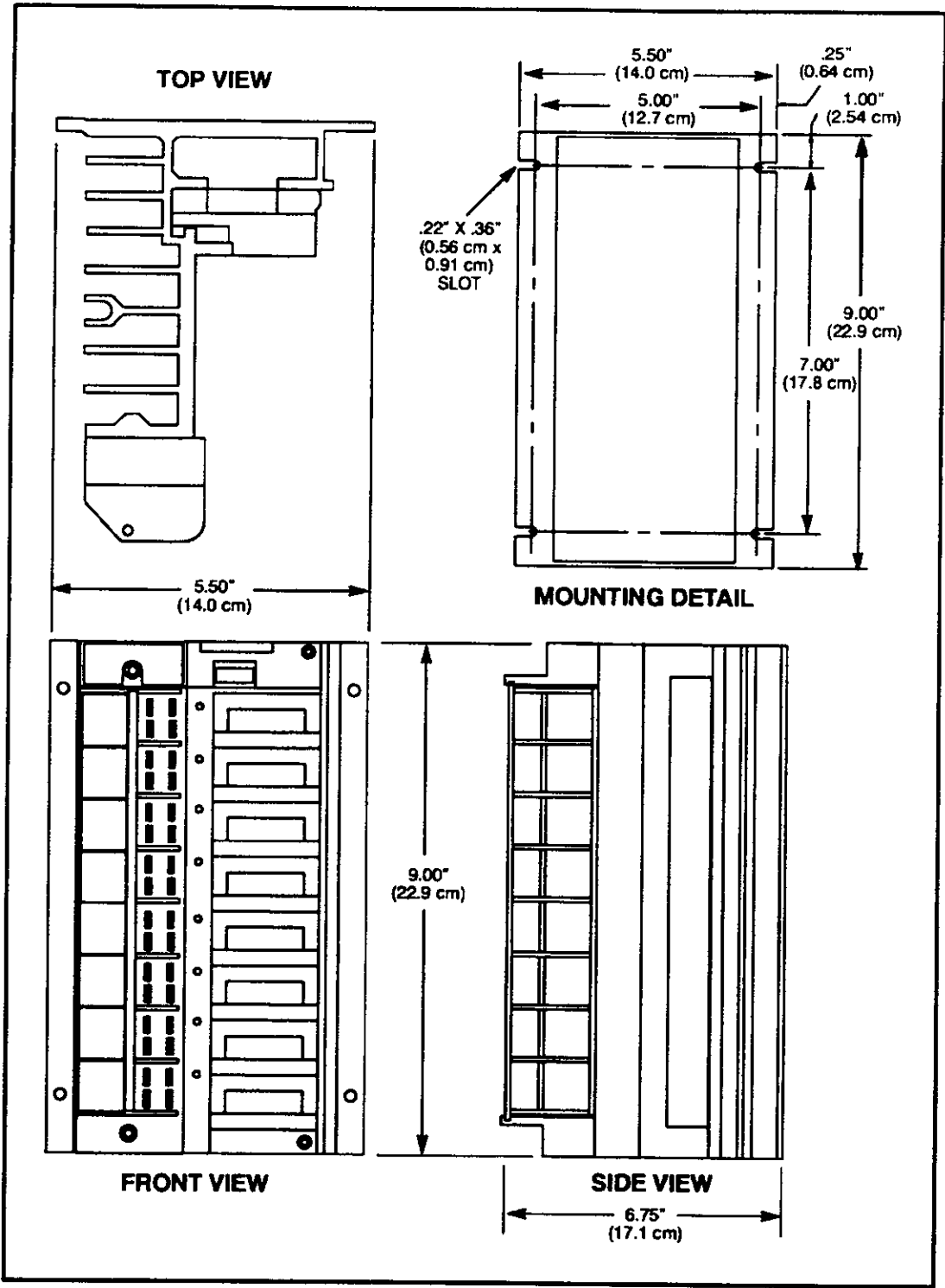

Figure 2.6 - Rail Mounting Dimensions

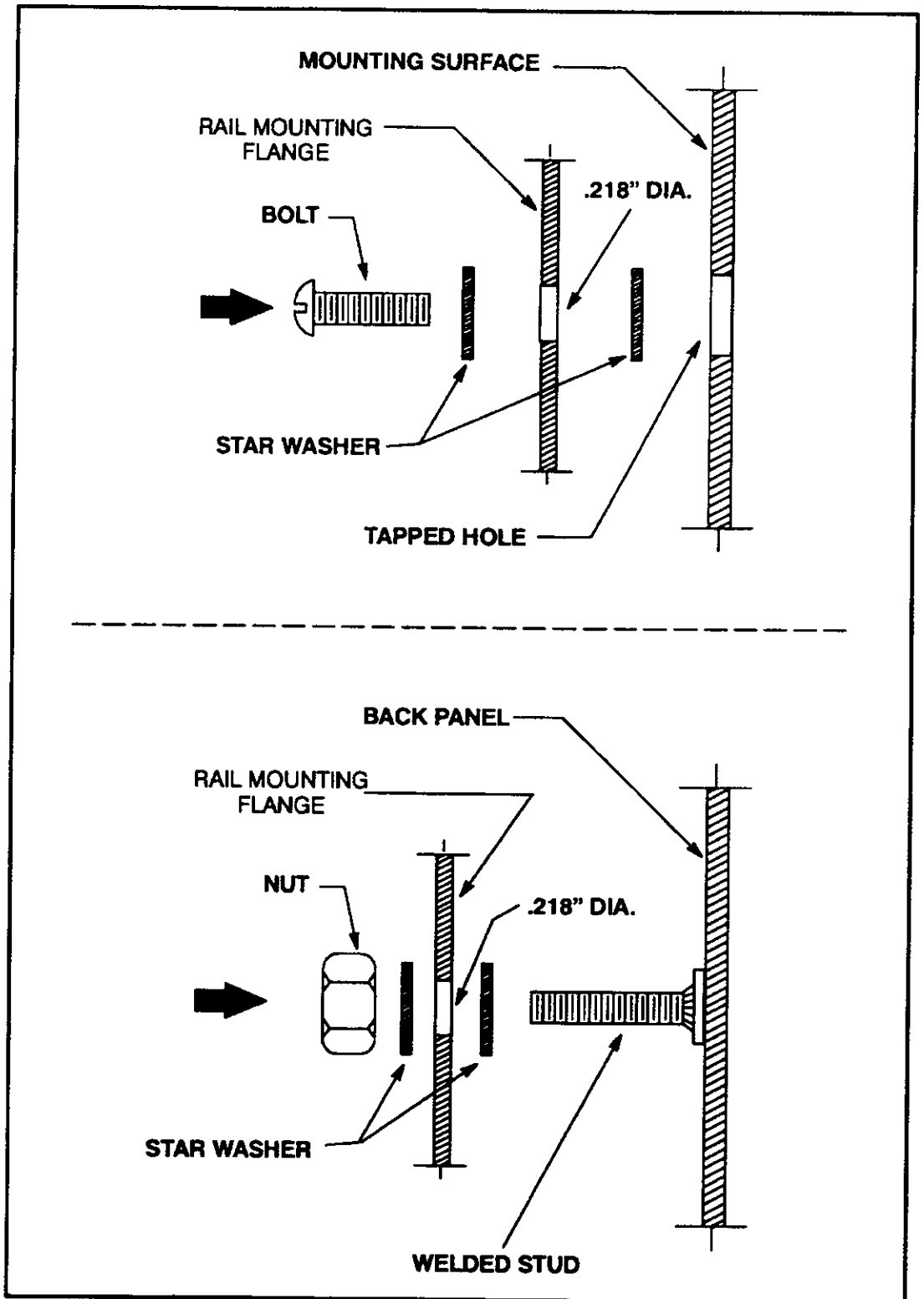

Figure 2.7 - Rail Mounting Examples

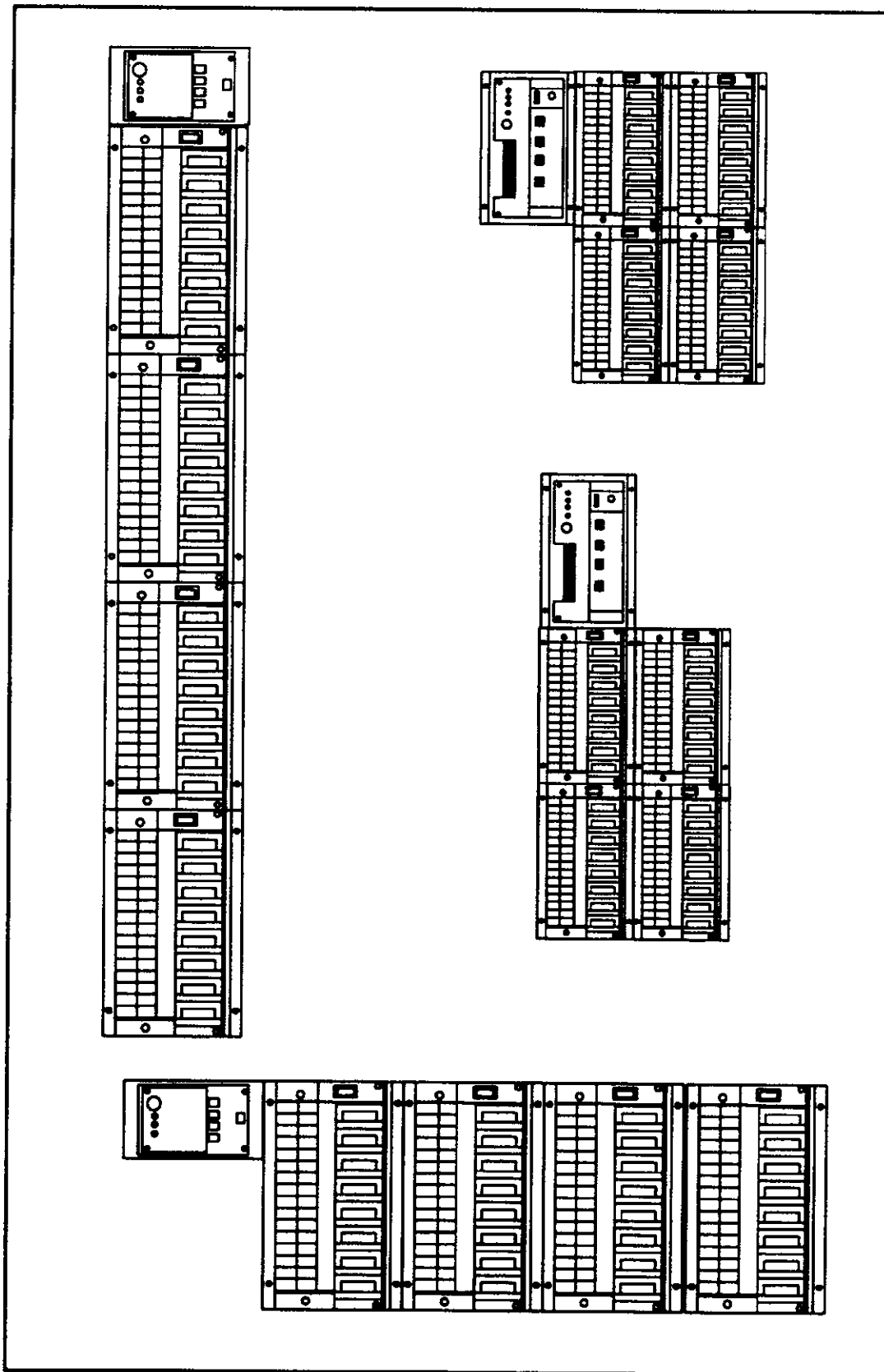

Figure 2.8 - Typical Rail Installations

2.3.1 Grounding

DANGER

THE USER IS RESPONSIBLE FOR CONFORMING TO THE NATIONAL ELECTRIC CODE AND ALL OTHER APPLICABLE LOCAL CODES WITH RESPECT TO WIRING, GROUNDING, DISCONNECTS, AND OVERCURRENT PROTECTION. FAILURE TO OBSERVE THIS PRECAUTION COULD RESULT IN SEVERE BODILY INJURY OR LOSS OF LIFE.

Rails must be grounded for proper operation. Grounding is important in that it not only reduces the risk of electrical shock but it also helps to eliminate electrical noise. The path to ground (using a 1KVA transformer) should have less than 10 milli-ohms of resistance. On each rail there are two #10 studs for grounding purposes. See figure 2.9.

The ground wire must be at least 14 AWG (2.1 mm²) with green insulation. Use a lug for a secure connection. Place a toothed lock washer under the lug to ensure a good ground.

If the rail is to be mounted on a properly grounded sub-panel, you can ground it through the sub-panel. You ground the rail through the sub-panel by removing the paint from the area where the AutoMate component will be mounted. Place a toothed lock washer between the sub-panel and the rail to ensure a good ground.

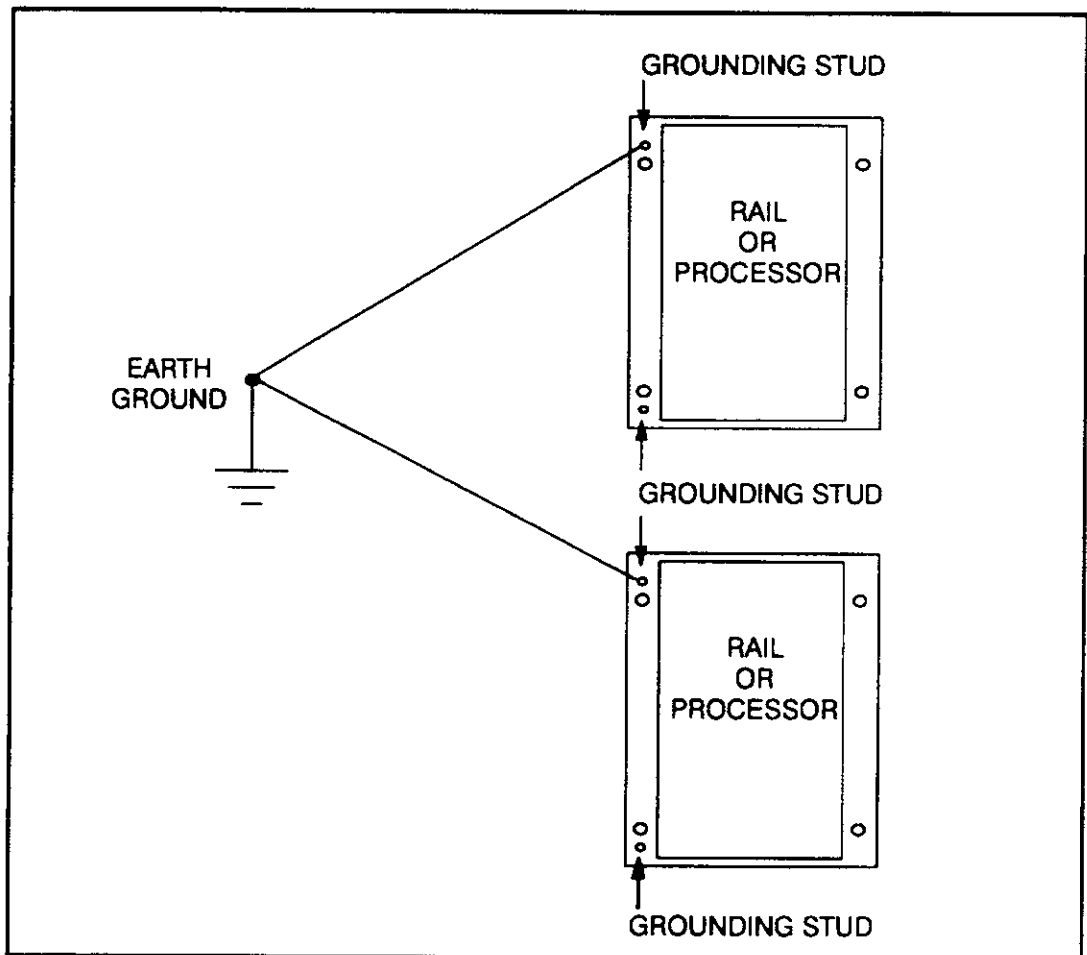

Figure 2.9 - Grounding

2.3.2 Rail Cabling Channel Kit

The I/O Rail Cabling Kit (M/N 45C4) consists of four sections of wire channel that can be mounted to the heat sink on the chassis of four rails.

This channel provides a housing for the field wiring connected to the rail's terminal strip. Figure 2.10 shows the wire channel fastened to the rail. The rail has a threaded groove on one of the cooling fins which accepts 10-32 screws that are 3/8 of an inch long. Screws are provided with each kit to mount the four channel sections. The wire channel measures 9.0 inches (22.9 cm) (H) x 4.0 inches (10.2 cm) (W) x 1.5 inches (3.8 cm) (D).

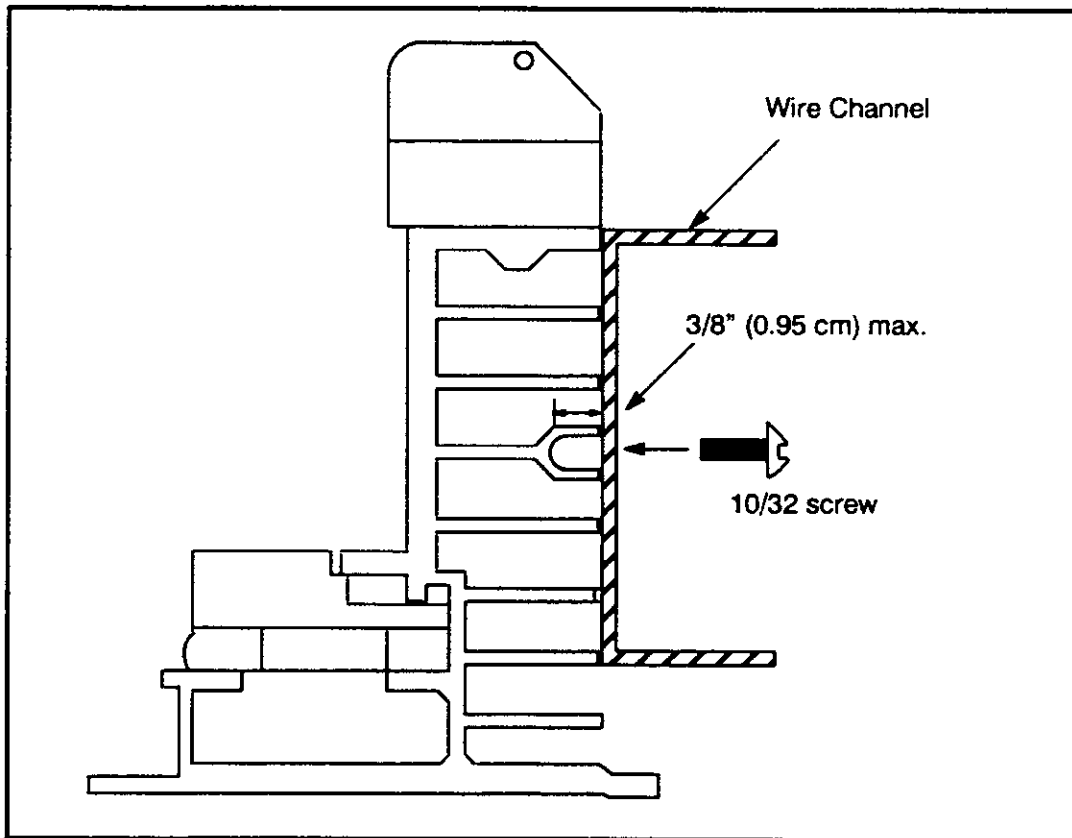

Figure 2.10 - Rail Cabling Channel

2.3.3 Horizontal I/O Cable Channel Kit

The Horizontal I/O Cable Channel Kit (M/N 45C7) is used to route the I/O Rail Cable when the cable cannot be run within the rail cable raceway.

Figure 2.11 shows the horizontal channel's dimensions. Figure 2.12 shows the typical rail layouts where the horizontal channel is used. Each kit contains five sections of the channel.

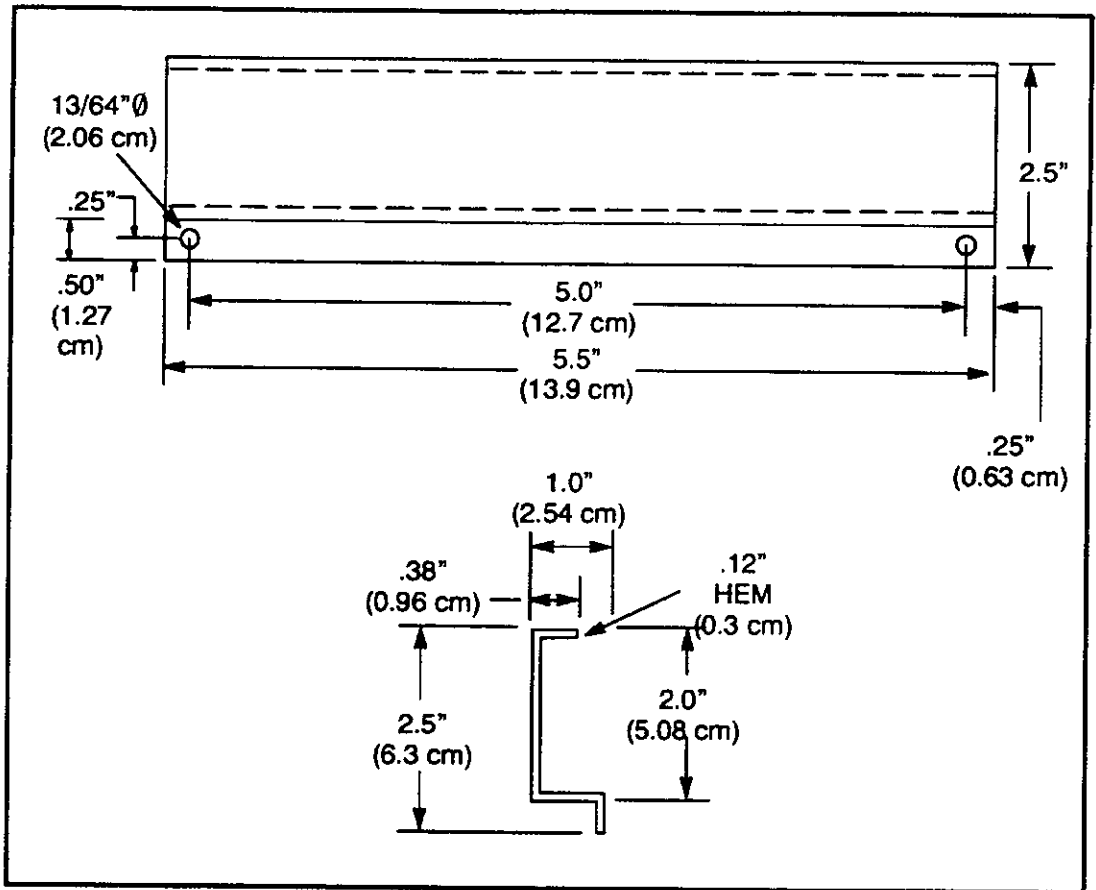

Figure 2.11 - Horizontal Channel Dimensions

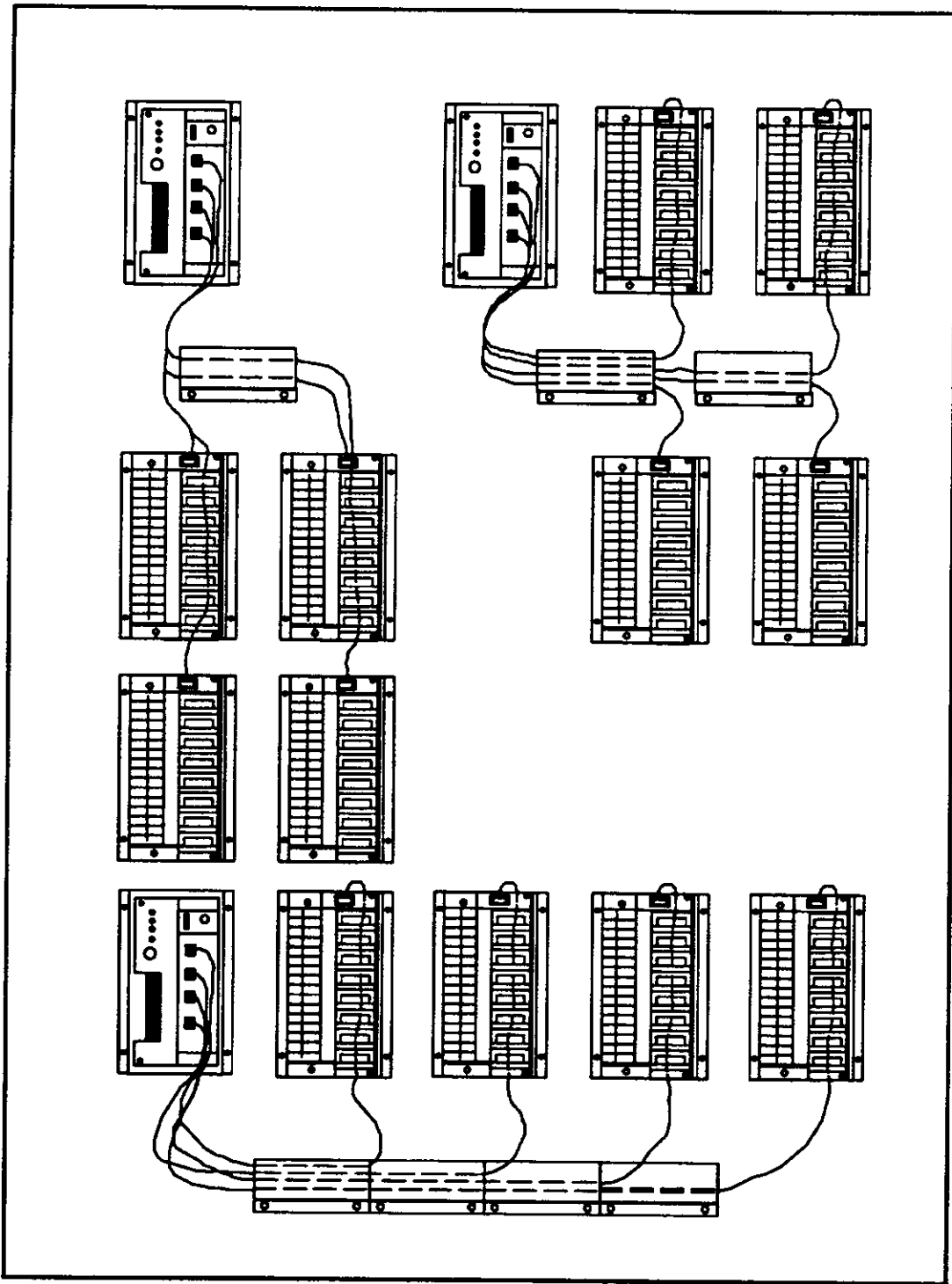

Figure 2.12 - Typical Horizontal Channel Applications

2.3.4 Rail Jumper Bar Kit

A Rail Jumper Bar (M/N 45C3) is used to tie two or more terminals together on the terminal strip. See figure 2.13. You can cut the jumper bar to any length you need for a particular installation.

Note that the jumper bar must be installed on the B terminals of the terminal strip. The jumper bar will not fit on the A terminals properly.

Figure 2.14 shows two jumper bars installed on the terminal strip. For clarity, the terminal strip cover is not shown in the figure.

When using a jumper to tie terminals together for inputs, the jumper is tying together the commons. When being used with outputs, a jumper is tying the power sides together.

DANGER

WHEN A JUMPER BAR IS INSTALLED YOU MAY BE EXPOSED TO HIGH VOLTAGE ON THE TERMINALS EVEN THOUGH THE TERMINAL STRIP COVER IS IN PLACE. DO NOT TOUCH THE TERMINAL STRIP WHEN POWER IS APPLIED. FAILURE TO OBSERVE THIS PRECAUTION COULD RESULT IN SEVERE BODILY INJURY OR LOSS OF LIFE.

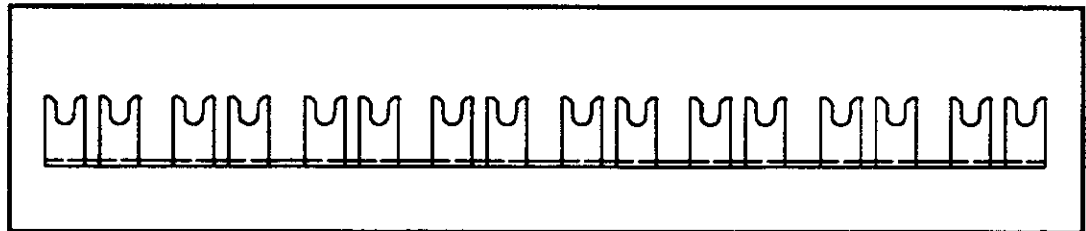

Figure 2.13 - Jumper Bar

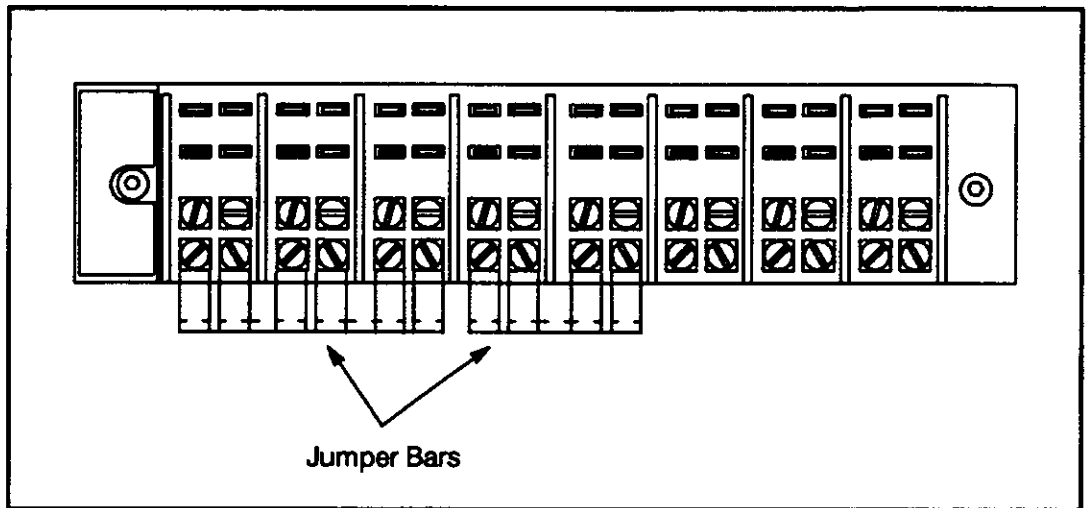

Figure 2.14 - Jumper Bar Installation

2.4 I/O Wiring

I/O wire identification labeling is provided on the terminal strip as described in section 2.2.2. Note that the I/O wiring cannot be larger than 12 AWG (3.30 mm²) or smaller than 22 AWG (0.32 mm²). Do not connect more than two wires per terminal. Even-number terminals connect to the modules' even-number channels (00, 02, 04, etc). Odd-number terminals connect to the modules' odd-number channels (01, 03, 05, etc).

Jumper connections can be made with either Jumper Bars (M/N 45C3) or 12 AWG insulated wire. On D-C output modules the internal fuse is located on the B terminal, which should be wired as the hot side. On A-C output modules, the internal fuse is located on the A terminal which should be wired as the hot side.

Figure 2.15 shows an example of the flexibility of the connections between the rail and field devices. Inputs are addresses 00 to 11. Outputs are addresses 12 to 17. The first seven inputs (00-06) have their commons connected together. The next three inputs have separate commons. Loads connected to outputs 12 through 15 are shown paralld. The last two outputs are shown individually isolated.

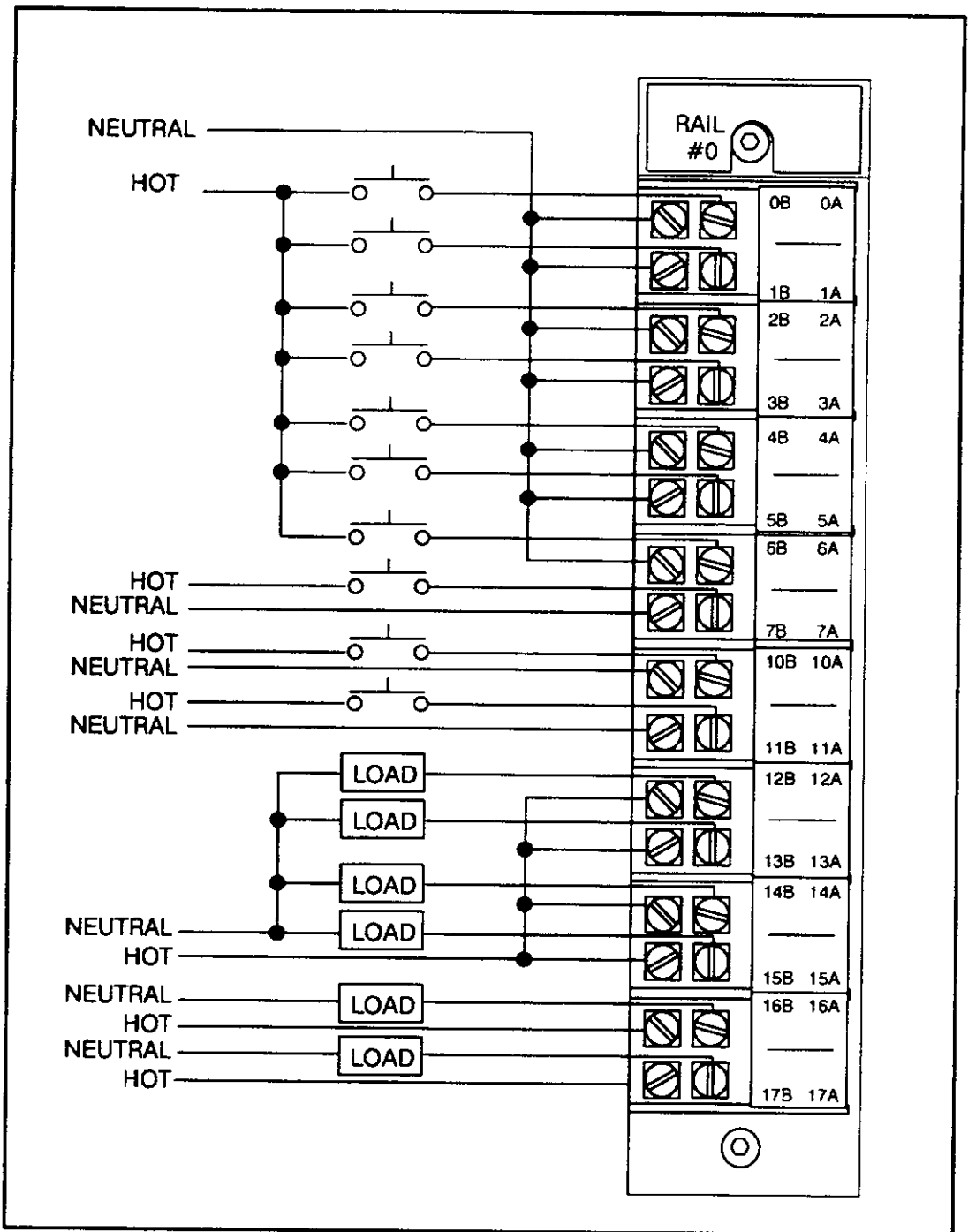

Figure 2.15 - Field Wiring Example

Use the following procedure to connect the I/O wiring:

DANGER

THE EQUIPMENT IS AT LINE VOLTAGE WHEN POWER IS CONNECTED. BE SURE TO DISCONNECT ALL POWER SOURCES BEFORE CONNECTING THE I/O WIRES TO THE RAIL. FAILURE TO OBSERVE THIS PRECAUTION COULD RESULT IN SEVERE BODILY INJURY OR LOSS OF LIFE.

DANGER

THIS EQUIPMENT MAY BE FED FROM MORE THAN ONE POWER SOURCE. DO NOT ASSUME THAT IT IS SAFE TO WORK ON WHEN ONLY THE MAIN POWER SOURCE IS DISCONNECTED. FAILURE TO OBSERVE THIS PRECAUTION COULD RESULT IN SEVERE BODILY INJURY OR LOSS OF LIFE.

- Step 1. Plan your wiring and jumper connections.
 - Step 2. Loosen the terminal screws to which the field wiring will be connected.
 - Step 3. Locate the wire that is to be fastened to terminal 17B of the rail.
 - Step 4. Bend the wire to create a neat wire bundle. If a wire tray is used, be sure the wire bundle is in the tray.
 - Step 5. Cut the wire. The wire should be 5/16 of an inch (8 mm) longer than is needed.
 - Step 6. Strip 5/16 of an inch of insulation from the end of the wire.
 - Step 7. Insert the wire under the terminal's pressure plate.
 - Step 8. Insert the jumper bar or wire, if used.
 - Step 9. Tighten the screw securely.
 - Step 10. Locate the wire that is to be fastened to terminal 17A of the rail.
 - Step 11. Bend the wire to create a neat wire bundle.
 - Step 12. Cut the wire 5/16 of an inch longer than is needed.
 - Step 13. Strip 5/16 of an inch of insulation from the end of the wire.
 - Step 14. Insert the wire under the terminal's pressure plate.
 - Step 15. Insert the jumper bar or wire, if used.
 - Step 16. Tighten the screw securely.
- Repeat steps 2 through 16 until all of the wires are attached.
- Step 17. Check your wiring and ground connections.
 - Step 18. Mark the terminal strip cover label with the proper wire numbers.
 - Step 19. Close the terminal strip cover over the terminals.

DANGER

IF THE TERMINAL STRIP COVER IS NOT IN PLACE, YOU MAY BE EXPOSED TO HIGH VOLTAGE ON THE TERMINALS. BE SURE THE TERMINAL COVER IS IN PLACE. FAILURE TO OBSERVE THIS PRECAUTION COULD RESULT IN SEVERE BODILY INJURY OR LOSS OF LIFE.

- Step 20.** Attach the module identification stickers to the side of the terminal strip next to the modules.
- Step 21.** Plug in the I/O modules by carefully pushing them into the rail's motherboard and terminal strip connectors. Secure the modules to the rail by tightening the screw on the front of each module.
- Step 22.** Restore power and test the system for proper operation.